

*SignPal*  
**Pumall**

# User's Manual

*P11 - 30*

*P11 - 60*

*P11 - 132S*



**GCC**  
The Electro-Optical Automation Provider

# Contents

---

Important information .....	I
Quick installation guide .....	II
About cutting tool .....	III
Checking Supplied items .....	IV
Chapter 1. Parts Names and Functions .....	1-1
1.1 Front view .....	1-1
1.2 Back view with stand .....	1-2
1.3 Side view .....	1-3
1.4 Control Panel .....	1-4
Chapter 2. Setup .....	2-1
2.1 Setting up .....	2-1
2.2 Stands and media support system installation.....	2-2
2.3 Power and cable connections .....	2-5
2.4 Blade installation .....	2-6
2.5 Media loading .....	2-9
2.6 Tracking performance .....	2-15
2.7 Dip switch setting .....	2-16
2.8 Power on .....	2-18
2.9 On/Off line key .....	2-19
2.10 Pause key .....	2-19
2.11 Repeat key .....	2-19
2.12 Data clear key .....	2-20
2.13 Origin setting .....	2-20
2.14 Cut test .....	2-21
2.15 When completing the cutting job .....	2-23
Chapter 3 Connecting cutting plotter .....	3-1
3.1 Universal serial bus .....	3-1
3.2 Parallel transmission .....	3-2
3.3 Serial transmission .....	3-2
Chapter 4 Virtual LCD .....	4-1
4.1 Installation .....	4-1
4.2 Before using VLCD .....	4-1
4.3 Functions of VLCD .....	4-2
Chapter 5 Basic Maintenance .....	5-1

5.1	Cleaning the cutting plotter .....	5-1
5.2	Cleaning the grid drum.....	5-1
5.3	Cleaning the pinch rollers .....	5-2
Chapter 6 Troubleshooting .....		6-1
6.1	If the cutting plotter cannot operate .....	6-1
6.2	Light indicators .....	6-1
6.3	Cutting quality problem.....	6-5
Appendix:		
1.	Specifications of Puma II .....	a
2.	Specifications of GCC blade .....	b

# IMPORTANT INFORMATION

Thanks for your purchasing of our SignPal Puma II series cutting plotters. For your safety and optimize the performance of the Puma II, please read user manual completely and keep it in a correct location.

## PRECAUTIONS IN USE

- For safety's sake, please always hold the cutter firmly from the bottom when moving it. Please hold from the bottom.

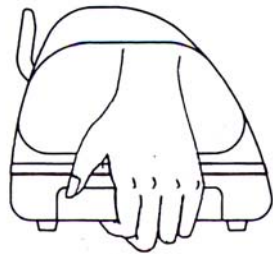

(O)

**hold from the bottom**

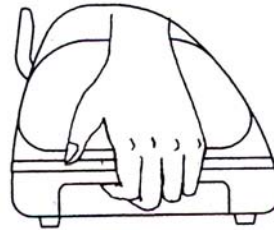

(X)

**hold the depression area**

- Do not shake or drop the blade holder, blade tip maybe fly out.
- During operation, keep away from any moving parts of the cutter (such as the carriage, drums). Also be careful that clothing and hair do not be caught.
- Connect the power cable to a grounded outlet.
- Always use the accessory power cable that is provided. Do not wire the power cable so that it becomes bent or caught between objects.
- Do not connect the power cable to branch outlet to which other machines are also connected, or use an extension cable. There is danger of overheating and of mis-operation of the machine.
- Keep the blade away from children.
- Always put the pinch rollers within position of the white marks.

# QUICK MENU

1. Power **ON**. (The POWER LED lights on)
2. Note: Make sure the level is up before placing the media on the plotter. Place the media and pull the level to lower down the pinch rollers (must be sure the pinch rollers are position above the grid drums, that is, within the white marks).
3. **Puma II will take about 10 sec to initialize the machine.** Then the cutter will size the media automatically according to set of the dip switch (usually the presetting is EDGE media type).
4. Off-line condition – Plotter is not ready to receive data from computer. Press **ON/OFF LINE** key, the LED above the key turns off.
5. On-line condition - Plotter is ready to receive data from computer. Press **ON/OFF LINE** key, the LED above the key lights.
6. Change the setting value during cutting. Press **PAUSE** key, the LED above the key flashes. To continue cutting press **ON/OFF LINE** key.
7. Terminate the cutting and clear the data in the buffer. Press **ON/OFF LINE** key or **PAUSE** key and then press **DATA CLEAR** key.

# About the Tool

A generic term refer to the blade that cuts the sheet, the pen that does plotting, and the LED bombsight (option) used for pointing to the reference point.

**OFFSET** is the distance that the blade tip is displaced from the centerline of the blade.

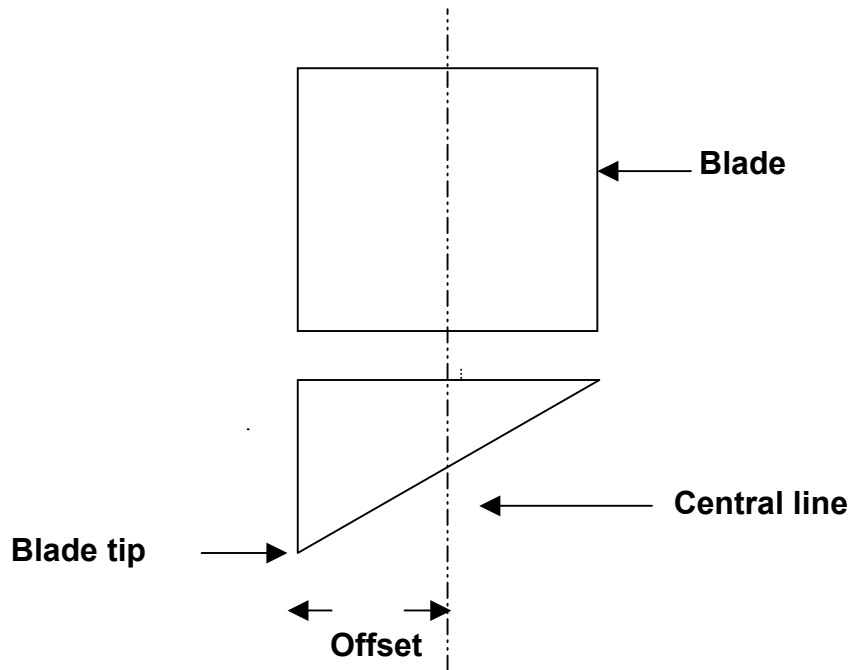

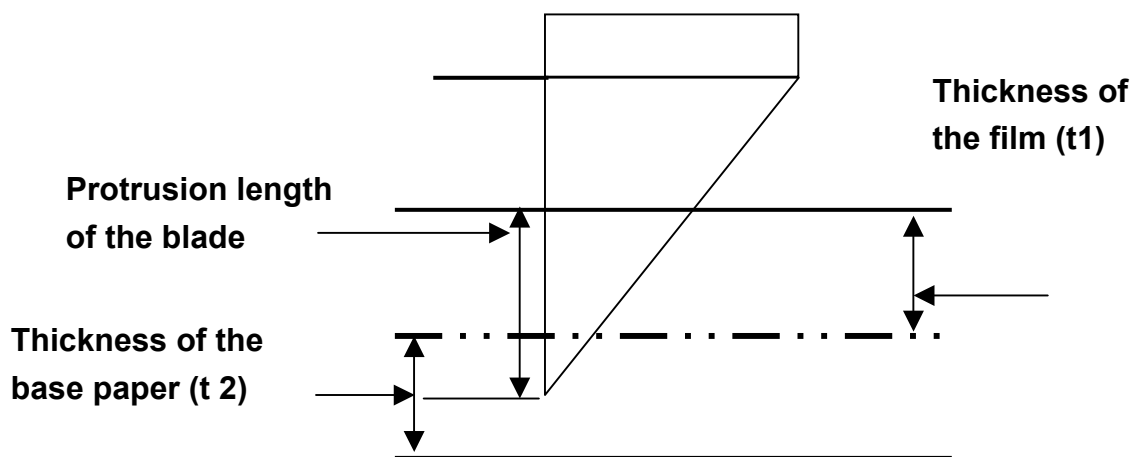

## Protrusion Length of the Blade



Length of protrusion =  $t_1 + t_2 / 2$ , but for your convenience you may just make it about 0.3- 0.5 mm beyond the blade holder tip.

# Checking Supplied Items

<p><b>1. Installation CD</b></p> 	<p><b>2. Printer Cable</b></p> 	<p><b>3. AC Power Cable</b></p> 
<p><b>4. RS232 Cable</b></p> 	<p><b>5. Blade Holder &amp; Fiber Tip Pen</b></p> 	<p><b>6. Cutting Strip (Pad)</b></p> 
<p><b>7. Safe Blade</b></p> 	<p><b>8. USB Cable</b></p> 	<p><b>9. Error-Correct &amp; Function Sticker</b></p> 
<p><b>10 Roll Base (only for PII-30/60)</b></p> 	<p><b>11. Tweezers</b></p> 	<p><b>12. Knife</b></p> 

# Chapter 1 Parts Names and Functions

## 1.1 Front View

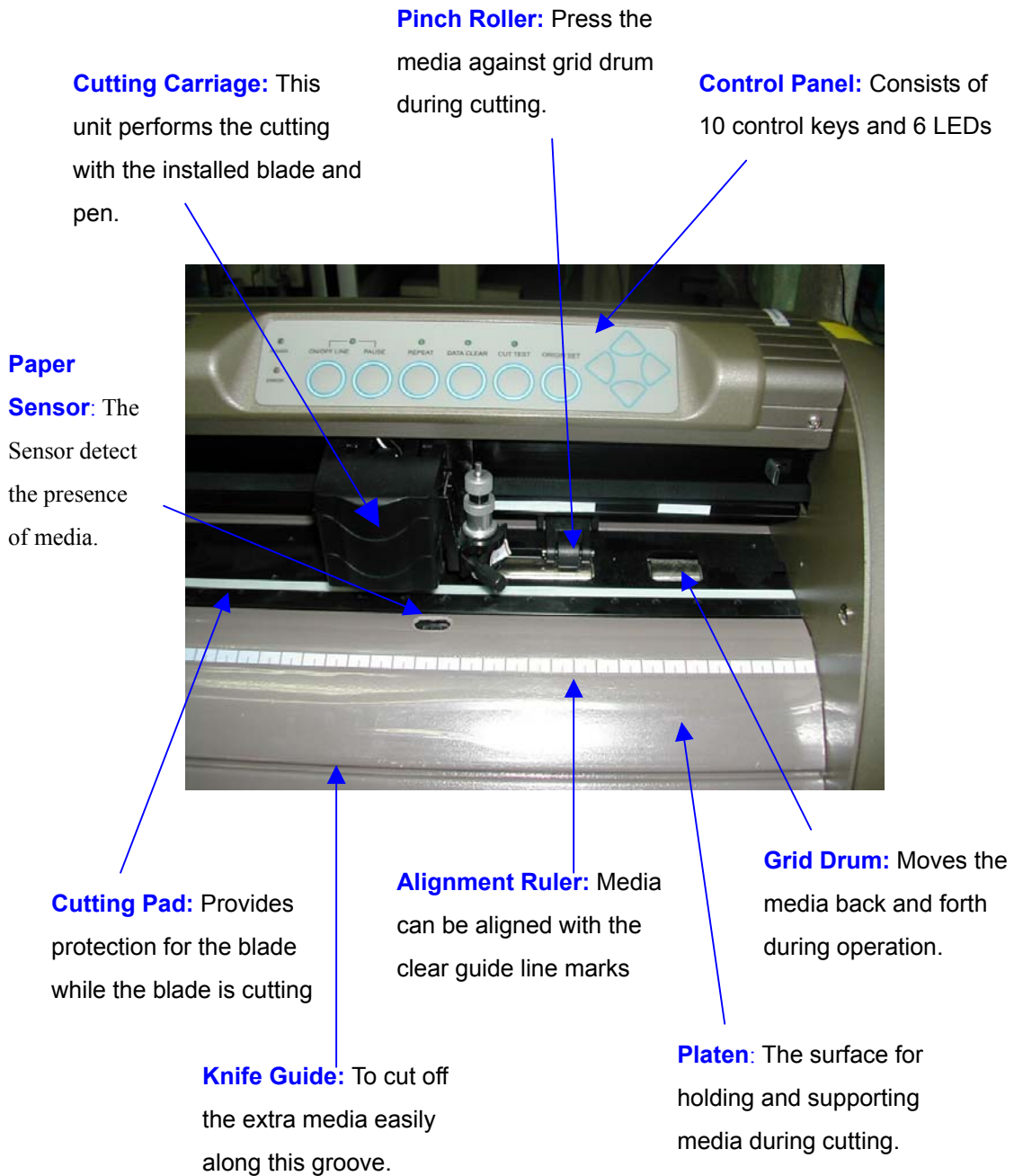

Figure 1-1 Front view of Puma II



1-2 Back View of Puma II 132S with stand

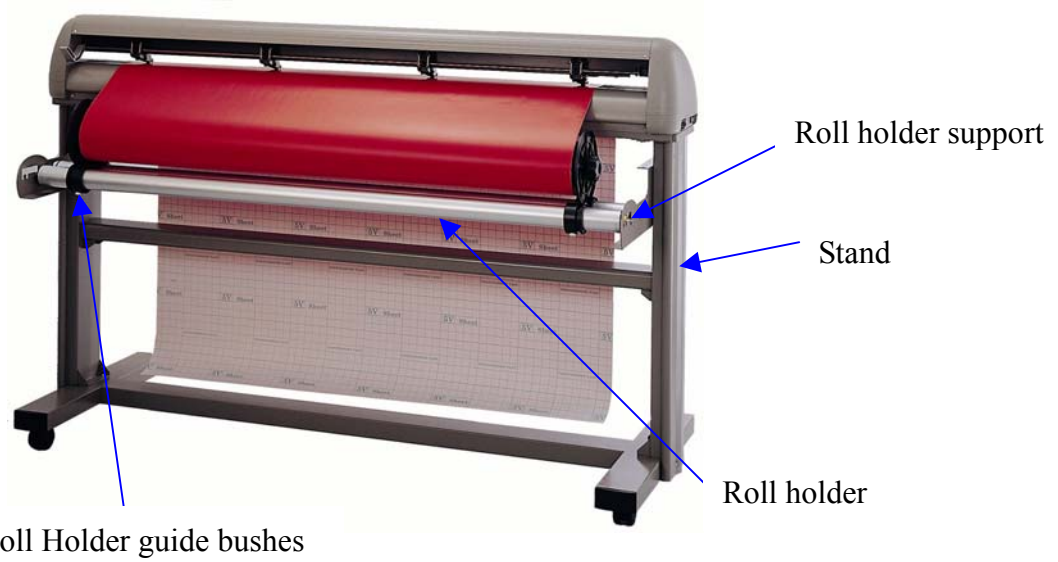

Fig 1-2 Back view of Puma II 132S with stand

### 1-3 side view of Puma II



Fig 1-3 Left hand side view of Puma II

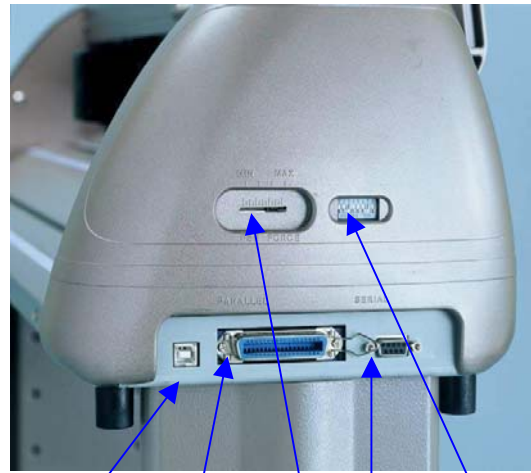

Fig 1-4 Right hand side view of Puma II

#### Left Hand Side (Figure 1-3)

1. **AC Power Connector** – Used to insert the AC power cord.
2. **Fuse** – Up to 3 Amp.
3. **Power Switch** – On when switches to [I]; Off when switches to [O]

#### Right Hand Side (Figure 1-4)

4. **USB interface Connector** - Used to connect the cutting plotter to a computer through a USB cable.
5. **Parallel Interface Connector (Centronics)** – Used to connect the cutting plotter to a computer through a parallel interface cable.
6. **Pen Force Control Slider** – Set the blade force here.
7. **Serial Interface Connector (RS-232C)** – Used to connect the cutting plotter to a computer through a serial interface cable.
8. **Dip Switch** - Used for various parameter setting.

## 1.4 Control Panel

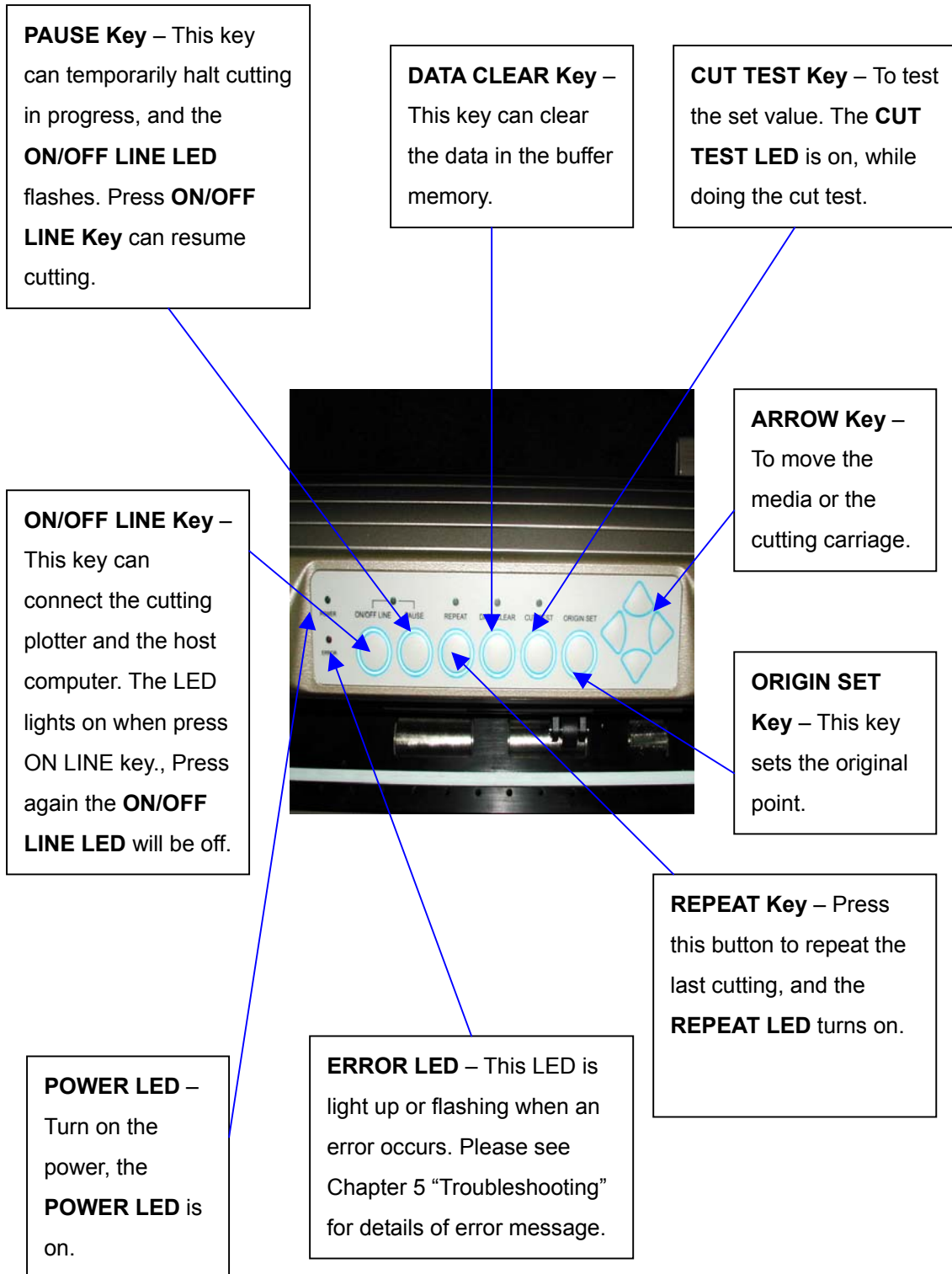

## Chapter 2 Set Up

### 2.1 Setting Up

#### **CAUTION!**

---

- ❖ At least two or more persons holding the **Puma II 132S** at its bottom surface on the left and right sides when you unpacking, installing or relocating the cutter.
  - ❖ Make sure the power switch is off before installing the cutting plotter.
- 

#### **Notice!** Choosing a proper place before setting up the cutting plotter

---

Select a proper location which meets the following conditions.

- ❖ The machine can be approached easily from any direction.
  - ❖ Keep at least 60 cm space in front and behind the machine.
  - ❖ Make sure the cutter is placed on a flat, level and sturdy surface
  - ❖ The working temperature should be between **5 and 40 (41-104°F)** in the workshop.
  - ❖ The relative humidity should be between **30% and 70%** in the workshop.
  - ❖ Protecting the machine from dust and strengthen air current.
  - ❖ Preventing the machine from direct sunlight.
-

## 2.2 Stands and Media Support System Installation

There are seven steps to assemble stand and media support system. Please follow the procedure:

**Step 1** Check screws and wrench in the accessory box of stand carton:

Items	Puma II 60/30	Puma II 132S
M6 screws	28	24
M5 L- shape hexagon screw driver	1	1
M6 L- shape hexagon screw driver	1	1
M6 wrench (spanner)	1	1

### Step 2

**Puma II 60 stand:** There are three components to assemble it. Please refer to Figure 2-1.

**Puma II 132S stand:** There are four components to assemble it. Please refer to Figure 2-1-1 and 2-1-2

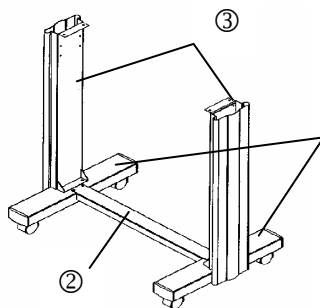

**Figure 2-1**  
(Puma II 60)

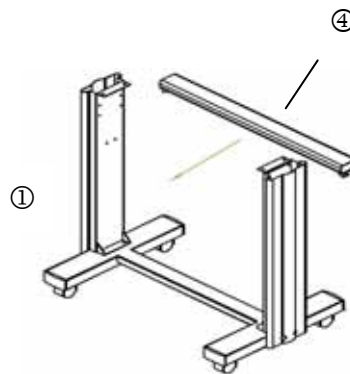

**Figure 2-1-1**  
(Puma II 132S)

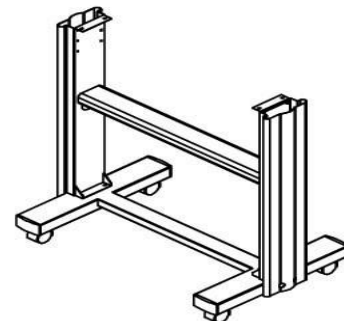

**Figure 2-1-2**  
(Puma II 132S)

### Step 3

Then connect part ③ and H-shape stand. First, position the extension of part ③ into the squares holes on H-stand. Second, insert the screws into the holes besides the squares then tighten them, see Figure 2-2.

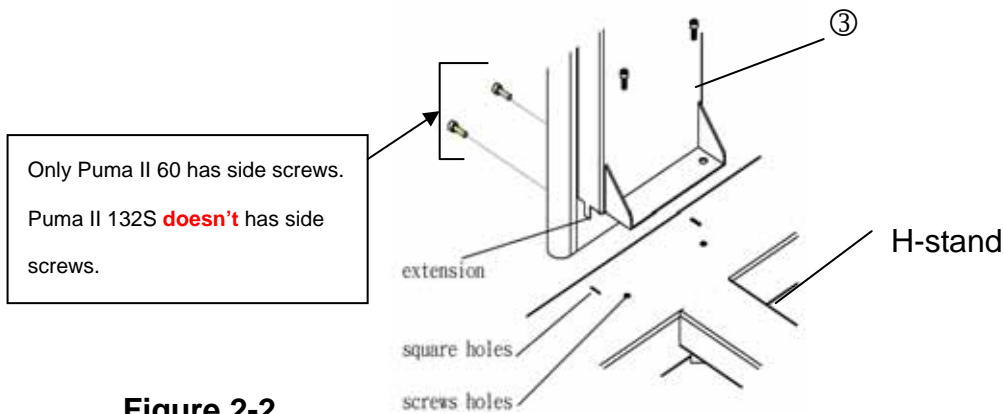

**Figure 2-2**

Third, (For Puma II 132S only) position the stand beam perpendicularly to part ③ and put the screws into the holes and tighten them as Figure 2-2-1.

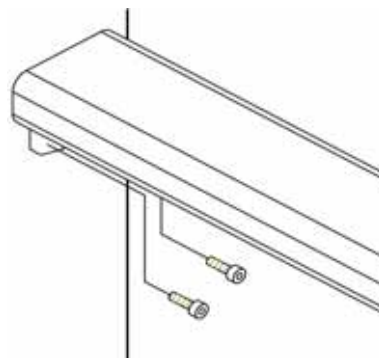

**Figure 2-2-1**  
(Only for Puma II-132S)

**Step 4**

Move the cutting plotter from the carton. Put it on the stand, then Insert the screws into the holes on plotter's bottom as Figure 2-3.

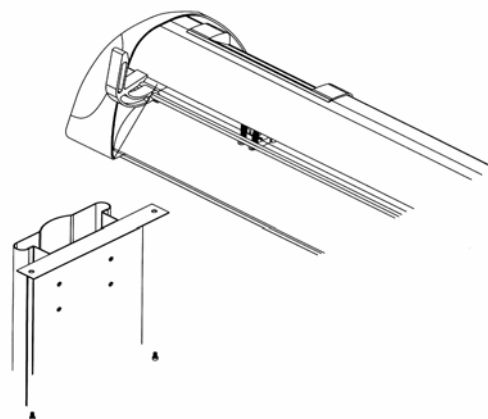
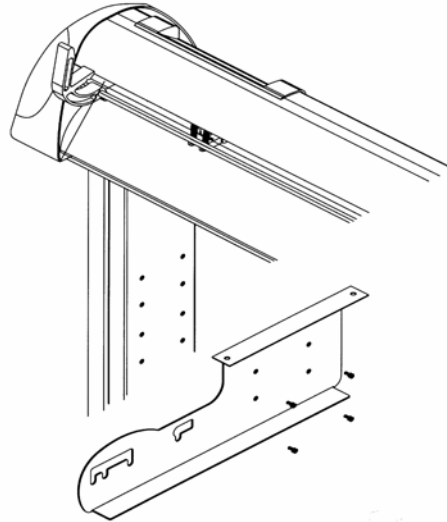

**Figure 2-3**

**Step 5**

Insert the roll holder support with the screws into the holes of the stand then tighten them as Figure 2-4. You can decide roll holder support's position by inserting into

different holes.



**Figure 2-4**

**Step 6**

Place two roll holders into the holes in the roll holder support (Figure 2-5).

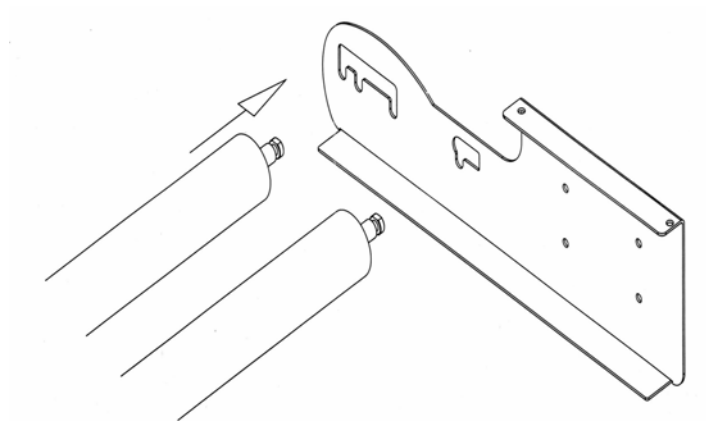

**Figure 2-5**

## 2-3 Power and cable Connection

### **! Notice**

---

Check the plug of the power cord to see if it mates with the wall outlet. If not, please contact with your dealer

Be sure that the power to both the computer and the main unit is switched off when connecting the cable

---

### **! Warning** Connecting the Power Supply

---

- ❖ Ground the unit with the ground wire.

---

- ❖ Insert the plug (male) into a grounded power outlet.
- ❖ Insert the other end (female) of power cord into the AC connector of the cutting plotter.
- ❖ Securely connect the power cord, Computer I/O cable and so on so that they will not be unplugged and cause failure during operation.
- ❖ Connect the cable to either the parallel or the serial port.



## 2.4 Blade Installation

### ! CAUTION

---

Do not touch the tip of the blade with your fingers.

---

### ! Notice

---

The blade will affect the cutting quality significantly. If any of the following occurs, which means the blade has reached the end of its life. Please replace with a new blade.

1. The tip of blade is broken.
  2. Cutting traces are not as good as they were.
  3. Uncut area remains the same even the blade force has been raised significantly.
- 

Figure 2-7 is the illustrator of the blade holder. Insert a blade into the bottom of the blade holder and remove the blade by pushing the pin. Be sure to keep your fingers away from the blade tip.



Figure 2-7

### Step1

Install blade (Figure 2-8).



Figure 2-8

### Step 2

Push the blade to the bottom of the blade holder. (Figure 2-9).



Figure 2-9

### Step 3

Adjust the blade tip to suitable length by screwing “Blade tip adjustment screw” clockwise or count-clockwise (Figure 2-10).



Figure 2-10

#### **Tips:**

“The proper length” means the blade’s length is about 0.1mm more than film’s thickness. For example, if the thickness of film is 0.5mm, then blade’s length is properly adjusted to 0.6mm and it can completely cut through the film layer but will not cut through the paper backing (See Figure 2-10).

**Step 4**

Insert the blade holder into tool carriage. Please note the outward ring of the holder must put into the grooves of carriage firmly (see Figure 2-11) and lock the grip



**Figure 2-11**

**Figure 2-12**

**Step 5**

Use the reverse steps to remove the blade holder.

**Step 6**

Press the push - pin to remove the blade from the blade holder when the blade needs to be replaced. Please refer to Figure 2-9 for reference.

## 2.5 Media Loading

### 2.5.1 Loading the Sheet Media

To load the media properly, please follow the procedures listed below:

1. Pull the lever forward to raise the pinch rollers (Figure 2-13).



**Figure 2-13**

Load your media on the platen and slide it under the pinch rollers from either the front side or the backside. The **alignment rulers** on the platen extension will help you to adjust the media precisely.

**Note:**

Be sure that the media must cover the paper sensors on the platen when loading the media. At least one of the two paper sensors (Fig 1-1) should be covered. Once the media covers the sensor, the cutting plotter will size the media's width and length automatically.

## 2.5.2 Positioning pinch rollers

Then move the pinch rollers manually to the proper position. Be sure the pinch rollers must be positioned above the grid drum. The **white marks** on the main beam will help you to position pinch rollers easily and correctly. (Figure 2-14).



**Figure 2-14**

Push the lever backward to lower down the pinch rollers.

Turn on the power, the tool carriage will measure the size of the media automatically. And the plotting cutter begins to work.

**Note:**

Move the pinch roller by applying force at the rear portion of the pinch roller support. Do not move it by holding its front rubber roller.



**Figure 2-15 Correct way to move pinch rollers**

### **2.5.3 Loading the Roll Media**

**First**, put the roll media guide bushes on two roll holders (Figure 2-16).

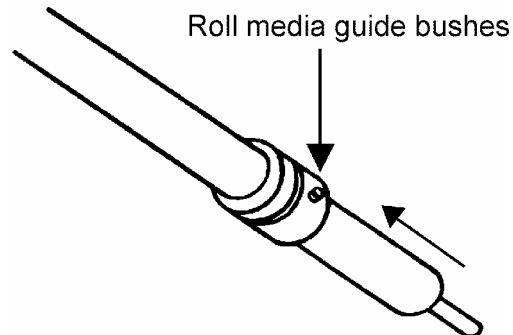

**Figure 2-16**

#### **Option A (Recommended)**

Insert the two roll holders into the roll media support set then place the roll media directly between the two roll holders (Figure 2-17).

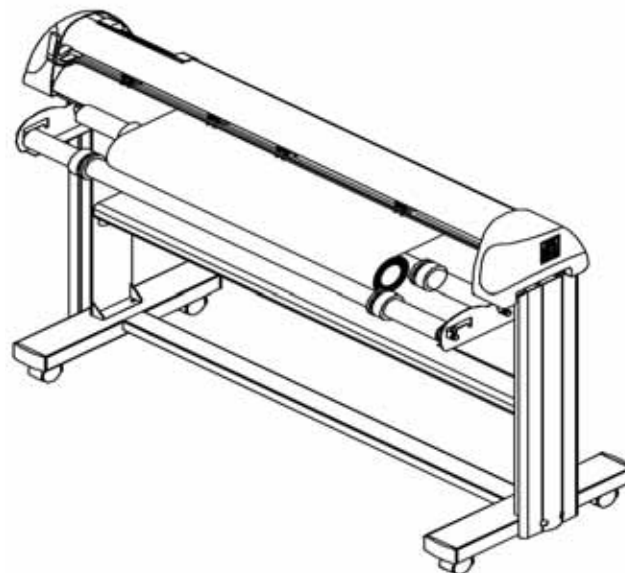

**Figure 2-17**

**Option B (Use the media flanges)**

1. Insert a roll media flange at the end of each roll media and tighten the thumbscrew until the roll media is firmly gripped (Figure 2-18).

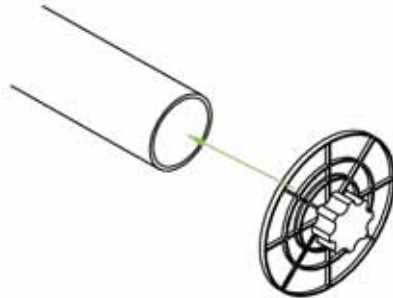

**Figure 2-18**

2. Then put the roll media on the roll holders. Adjust the position of the roll media ensure that media flanges are able to run in the grooves of media guide bushes. (Figure 2-19)



**Figure 2-19**

3. Loading the media on the platen. **After** loading the roll media, flatten the media on the platen and hold the front edge of the roll media firmly (Figure 2-20).

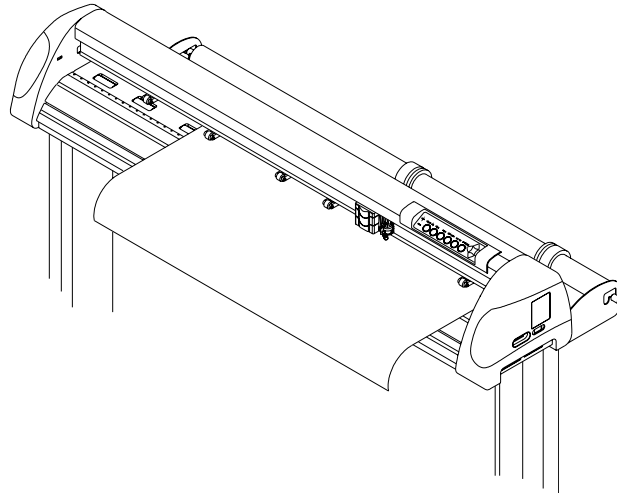

**Figure 2-20**

4. Then turn the roll downward to make an equal tension across the media. (Figure 2-21)

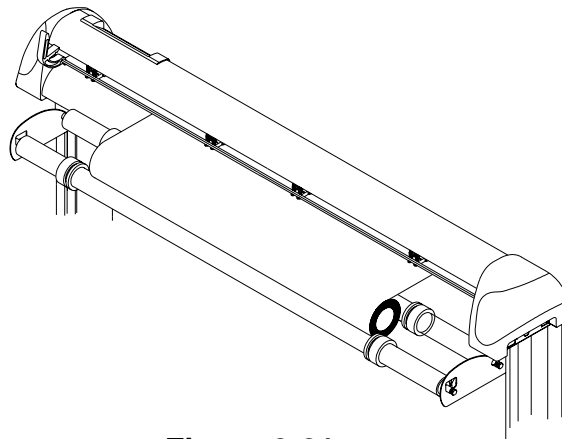
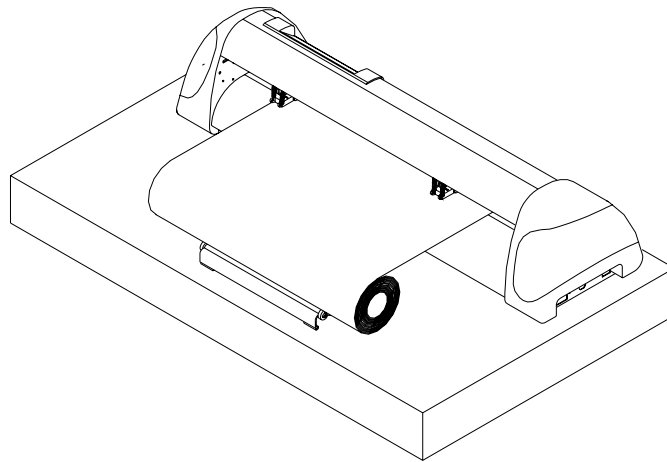

**Figure 2-21**



5. Move the pinch rollers to the appraise location and be careful that the pinch rollers must be positioned above the grid drums.
6. Push the lever backward to lower down the pinch rollers.
7. Fixes roll media guide bushes on the roll holder to secure the roll media.
8. Turn on the power switch, and the tool carriage will size the media automatically. Then the cutting plotter is ready to work.
9. Use the reverse steps to remove the media.

**For the users of Puma PII-30 or PII-60, you can also use the Roll Base to feed a roll media. Please adjust the position of roll base to get a good cutting result. (Figure 2-22)**

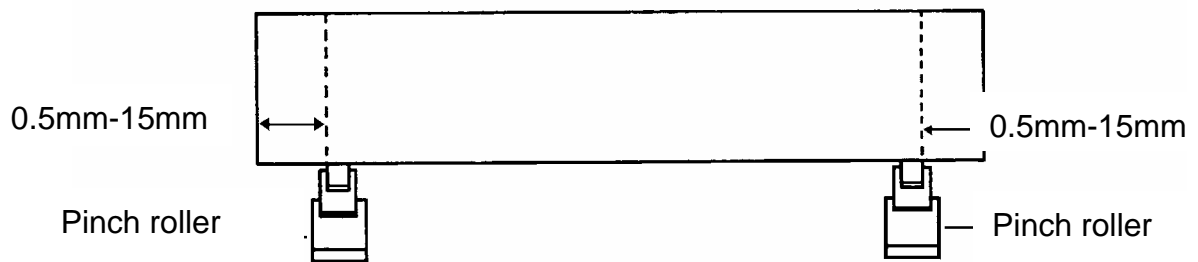

**Figure 2-22**

## 2.6 Tracking Performance

In order to achieve the best tracking performance for a long plot, we recommend some significant media loading procedures described as follows:

1. If the media length is less than 4 m, leave the margin of 0.5mm~15mm in the left and right edges of the media (see Figure 2-23).



**Figure 2-23**

2. If the media length is greater than 4m, leave at least 25mm margin on the left and right edges of the media (see Figure 2-24).

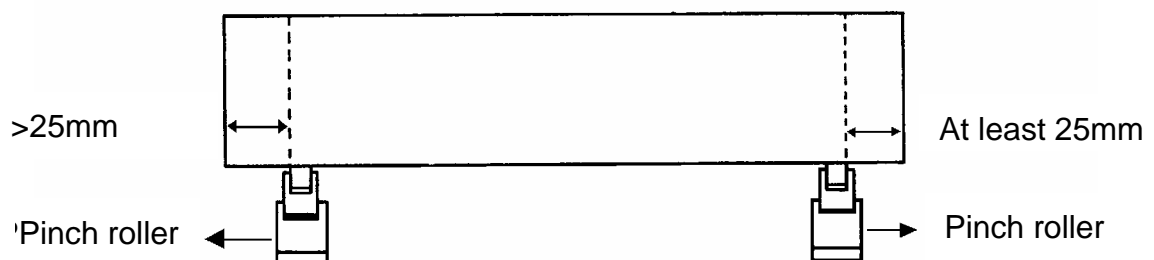

**Figure 2-24**

## 2.7 Dip Switch Setting

To get a perfect cutting job, you have to choose the proper Dip Switch setting. The table below shows function of each Dip Switch. The cutting plotter will read values of Dip Switches every time when press **ON/OFF LINE** key.

**\*\*Dip Switch setting change during on-line condition will not work.**

You can change the setting by pressing PAUSE key or when the plotter is in off-line condition. The default setting value is as Figure 2-25.

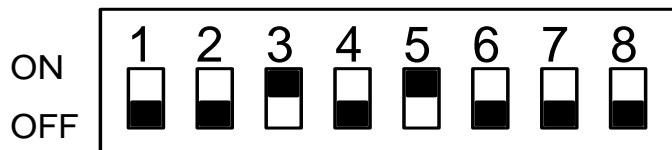
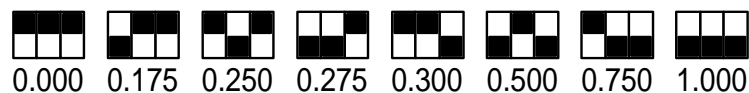

**Figure 2-25**

Dip Switch	Function	Switch Down	Switch Up	Default Value
SW 1-3	Offset Value	(Please refer to SW 1-3)		0.275 mm
SW-4	Media Weight	Light	Heavy	Light Media
SW-5	Quality	Draft	Fine	Fine
SW-6	Smooth	Enable	Disable	Enable
SW-7	Auto Unroll	Enable	Disable	Enable
SW-8	Media Type	Edge	Single	Edge

### **SW 1-3 : OFFSET SETTING**

The first three Dip Switches represent 8 different blade offset values as below:



### **SW-4 : MEDIA WEIGHT (SPEED)**

The fourth Dip Switch from the left sets the maximum cutting speed. Heavy media has a smaller upper limit. The value of the cutting speed can be changed from the driver

- When switch to "Heavy media", the maximum cutting speed is set at 300mm/sec, minimum cutting speed is set at 30mm/sec
- When switch to "Light media", the maximum cutting speed is set at 600mm/sec, minimum cutting speed is set at 330mm/sec.

## **SW-5 : QUALITY**

There is a trade-off between cutting quality and speed, the better the cutting quality, the slower the cutting speed.

- Fine quality
- Draft quality

## **SW-6 : SMOOTH**

Make the curves smoother during cutting.

\*\*When cut the small letter, please set smooth disabled to cutting quality smooth setting.

- Disable the smoothing cut.
- Enable the smoothing cut.

## **SW-7 : AUTO UNROLL**

Unroll the heavy media at least 50 cm when the next point of movement is located beyond the unrolled position. As the media type is Single, this function will be disabled.

- Disable the auto unroll
- Enable the auto unroll

## **SW-8 : MEDIA TYPE**

Set the type of the media you use. When using a piece media, set it to "ON"; and set it to "OFF" when using a roll media.

- Single sheet of media is using.
- A roll of media is using.

## 2.8 Power On



- ✧ Be sure not to put anything or hands on the platen of the plotter when turning on the power. It may cause injury.
- ✧ Keep long hair away from the grid drum when power is on..

Turn on the power on the left-hand side of the cutting plotter and the POWER LED is on.

**Notice:** It will take about 10 sec to initialize the machine, the cutting plotter is ready to receive data from computer. As bellowing is control panel lights when uses different functions key in normal conditions.

Function	POWER	ERROR	ON/OFF LINE	REPEAT	DATA CLEAR	CUT TEST
on-line state	●	○	●	○	○	○
pause state	●	○	☀	○	○	○
off-line state	●	○	○	○	○	○
repeat	●	○	○	●	○	○
data clear	●	○	○	○	●	○
cut test	●	○	○	○	○	●
origin set	●	○	○	●	●	●



= flash

● = on

○ = off

## 2.9 ON/OFF LINE Key

### **\*\*On - line**

When the machine is in “**ON LINE**” condition. The ON/OFF LINE LED is on. The cutting plotter is ready to receive data from the host computer. At this moment, only “**PAUSE**” and “**ON/OFF LINE**” keys are valid.

### **\*\*Change the setting value**

1. Press the **PAUSE** key. Then switch the dip to **change the setting value**.
2. Press the **ON/OFF LINE** key to effect new setting and **continue cutting**.

### **Note :**

The parameters of dip switch can not be changed while the cutting has started unless pressing the “**PAUSE**” key. When press the “**PAUSE**” key, you can change the setting.

### **\*\*Terminate the cutting & clear the data in the buffer**

1. Press the **ON/OFF LINE** or **PAUSE** key
2. Then press the **DATA CLEAR** key

### **\*\*Off - line**

When the machine is in “**OFF LINE**” condition, the **ON/OFF LED** turn off. At this moment, you can switch dip setting, make cutting test to adjust blade pressure and set new origin. Press the key again will let the cutting plotter switch back to “**ON LINE**” condition, and resume the suspended operation. But there might be some data loss during this interruption.

## 2.10 PAUSE Key

The purpose of the “**PAUSE**” key is to temporarily terminate the motion of the cutter after it started cutting. At this moment, the **ON/OFF LINE LED** flash; you can change the dips switch setting and the cutting force. It will resume cutting after pressing the **ON/OFF LINE** key to make the machine in on-line status.

## 2.11 Repeat Key

You can cut your last cutting job at the same position by pressing **REPEAT** key without setting new origin. If you're using a thicker media, it is better to use this function to avoid

damaging your blade.

**\*\* Procedures to repeat cutting job at different position:**

1. After cutting finishes, use the **ARROW** keys to move the tool carriage. Move to your desired position for repeating the cutting job, then press the **ORIGIN SET** key. The **ORIGIN SET LED** lights, and new origin point is set.
2. Press the **REPEAT** key to repeat the cutting job, and the **REPEAT LED** lights.

## **2.12 DATA CLEAR Key**

The purpose of the **DATA CLEAR** key is to clear the data in the buffer memory. The **DATA CLEAR** key can only works under pause or off-line condition. When use this function, the **DATA CLEAR LED** will light.

## **2.13 Origin Setting**

Use the **ORIGIN SET** key to set a new origin at any position in the cutting area where the tool carriage starts to work. Please note new origin setting must be made under the off-line condition.

**Procedures :**

1. After loading the media and lowering down the level, use **ARROW** keys to move the carriage to the desired location for a new origin.
2. Press **ORIGIN SET** key and the original point is set. The **ORIGIN SET LED** lights.

## 2.14 Cut Test

Before carrying out actual cutting, it is necessary to perform a cutting test to determine the appropriate cutting force and offset value for your media.

The cutting test should be repeated until you get an appropriate cutting condition.

Once you finish the cutting test, the new origin is also set to the current tool carriage position.

There are two adjustments you should do when perform cutting test. First one is cutting force adjustment; the second one is blade-offset adjustment.

### Procedures :

1. After sizing the media, press the **ON/OFF LINE** key to switch to off-line mode.
2. Then use arrow keys to move the tool carriage to the position where you will make cut test.
3. Press the **CUT TEST** key to make the cutting test. The **CUT TEST LED** turns on.

### 2.14.1 Adjust Cutting Force

First, move the “**Pen Force Control Slider**” to the min blade force, then increase the blade force gradually by moving the slider, until an optimum force is obtained to cut through the media.

When the cutting test is completed, a square cut out appears. If the square can be easily peel off from the media, the setting of cutting force is appropriate. If not, adjust the tool force again.

### 2.14.2 Adjust Offset Value

The square cut out should appear as one of the follow figure:

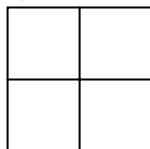

AA

Appropriate offset value

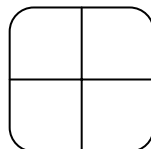

BB

offset too low

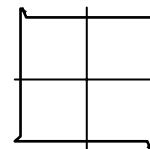

CC

offset too high  
Or over-speed



If the square appears BB or CC layout, adjust the OFFSET setting (please refer to paragraph SW1-3 OFFSET SETTING; Please also refer to the paragraph “**About the tool**” at the beginning of the book to learn the definition of offset.)

**Note:** The new origin will be set at the position of tool carriage after cutting test.

## 2.15 When Completing the Cutting Job

After completing the cutting, raise the sheet loading lever, then remove the material. You can also cut off the extra media with the cutter tool along the knife guide (Figure 2-25).



**Figure 2-25**

## Chapter 3 Connecting Cutting Plotters

The cutting plotter communicates with a computer through a **USB (Universal Serial Bus)**, **Parallel port (Centronics)** or a **Serial port (RS-232C)**. This chapter shows you how to connect the cutting plotter to a host computer and how to set up the computer/cutting plotter interconnection.

---

### !! Notice:

1. When USB connection is enabled, both parallel port and serial port will be disabled automatically.
  2. Please don't plug in USB cable when you install the driver
- 



**Figure 3-1**

### 3.1 Universal serial bus

Puma II build-in USB interface are based on the Universal Serial Bus Specifications Revision 1.1. USB is not available in Windows 95, Windows NT.

#### 3.1.1 USB driver installation

Insert "Installation CD", and then click on "USB driver" to install USB driver.

#### 3.1.2 Connection

Plug the cable connector into the Puma II's USB interface connector. Plug the other end of the cable into the PC's USB interface connector.

#### 3.1.3 Cutting driver or sign cutting software installation

Install Puma II driver or sign cutting software.

## 3.2 PARALLEL TRANSMISSION

### 3.2.1 Connecting to the Parallel Port (Centronics)

1. Connect a parallel cable to the cutting plotter and the host computer (Figure3-1).
2. Set up the output port **LPT1** or **LPT2** from your software package
3. Send the data to your cutting plotter directly. Or, use DOS commands like **TYPE** or **PRINT** to output data.

## 3.3 SERIAL TRANSMISSION

### 3.3.1 Connecting to the Serial Port (RS-232C)

1. For PC users, please connect the RS-232C cable to the serial connector of the assigned serial port (COM1 or COM2) of your host computer.
2. Set up the communication parameters (Baud Rate, Data Bits/Parity and Stop Bits) to match the setting on the computer.

### 3.3.2 Transmitting the Data to Plotter

There are two options to transmit the data from the computer to the cutting plotter:

#### **Option 1**

With proper interface settings, the data can be transmitted from your application software package to the cutting plotters directly.

#### **Option 2**

Most cutting software packages are able to emulate **HP-GL** or **HP-GL/2** commands, therefore, Use DOS commands like **TYPE** or **PRINT** to output your file. As long as the file is **HP-GL** or **HP-GL/2** format, the cutting plotter can output the data precisely.

For example, a file with **PLT** extension generated by **SignPal software, FlexiSign or SignLab** can be transmitted directly to the plotter at the DOS prompt, and then be cut out. Before outputting at the DOS prompt, set up a transmission protocol between your cutting plotter and computer by a DOS command, **MODE**. Make sure that your PC has the same communication protocol as the cutter. For example:

**MODE COM2: 9600,N, 8,1,P**

Then, use **TYPE** command to output via COM2 if COM2 is the assigned output port.

**TYPE filename > COM2**

**Tip:**

Add the **MODE** command line to your system's **AUTOEXEC.BAT** to automatically execute **MODE** command every time you want to output your data at the DOS prompt via serial connection. However, values in a **MODE** command should comply with the related requirements of your software. Refer to DOS manual for further information.

# Chapter 4 Virtual LCD

## 4.1 Installation

1. Start Windows 98, ME, 2000, or XP.
2. Insert “**Installation CD**” into your CD-ROM.
3. Click on “**installation of VLCD**”
4. Follow the appropriate screen prompts to install the VLCD™ program.

## 4.2 Before using VLCD™

This utility acts as a virtual display to assist you when checking the configurations in your cutting plotter.

To run this utility, simply execute it under Windows. Before starting the detection, **make sure:**

1. The cutting plotter is at the ON LINE status.
2. There is media in the machine.

## 4.3 Functions of VLCD™

Choose the right port whenever you use the VLCD (Figure 4.3.1). If you are using the USB cable, choose **USB0** from the pull down menu. If you are using a Serial cable, choose either **COM1** or **COM2**. Make sure no other devices are occupying the port that you are going to use.

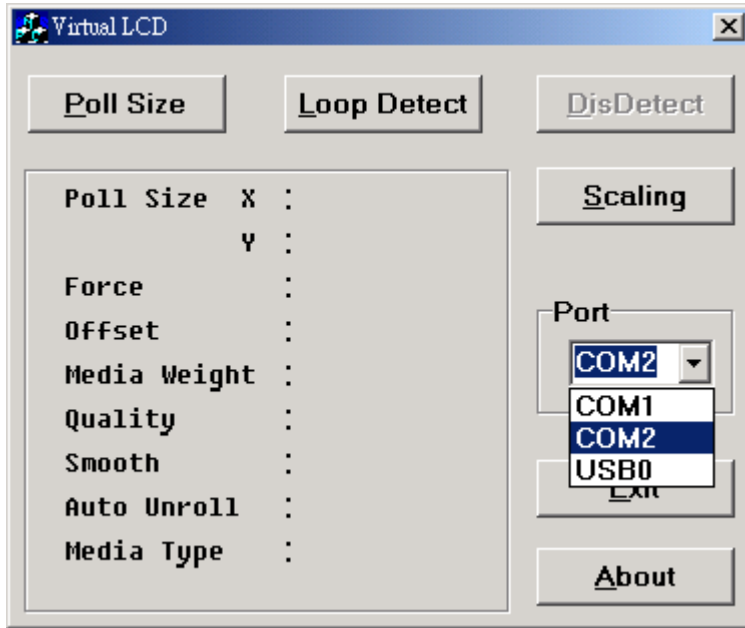

**Figure 4.3.1**

There are four functions available in VLCD: Poll Size, Loop Detect/DisDetect, Scaling, and About.

#### **A. Poll Size**

Clicking the **Poll Size** will reveal the X/Y values. In this case, the maximum cutting length is 25000mm, and the distance between the farthest two pinch rollers is 277.70mm (Figure 4.3.2).

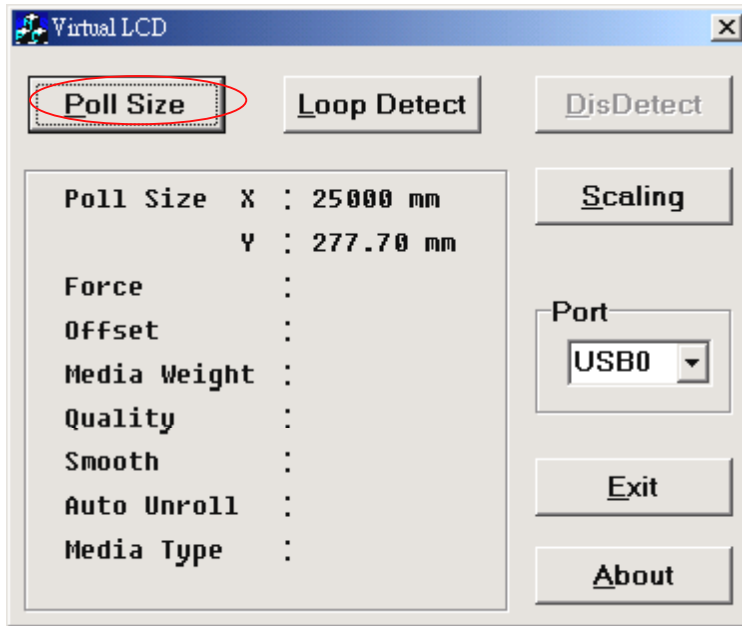

Figure 4.3.2

## B. Loop Detect and DisDetect

Clicking **Loop Detect** will reveal the value settings of your cutting plotter (Figure 4.3.3).

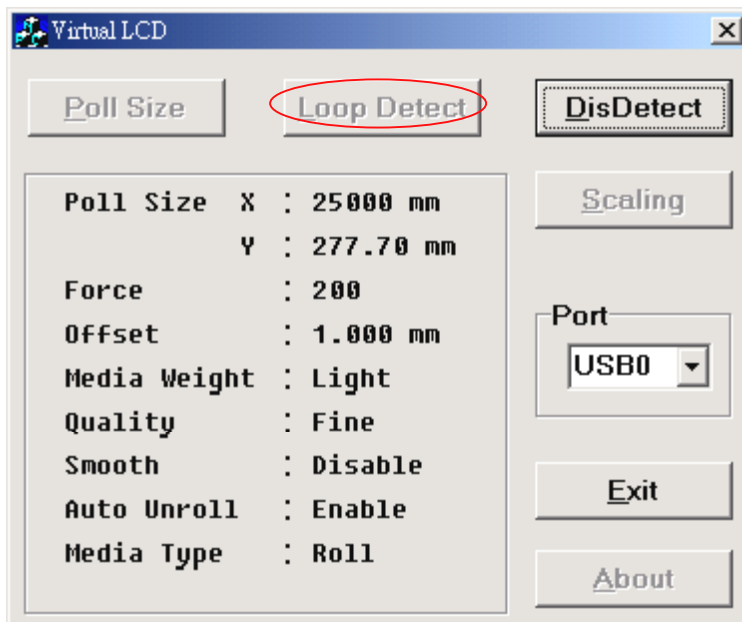

Figure 4.3.3

If you want to change the value settings, please click **DisDetect** first



(Figure 4.3.4), and adjust them from your cutting plotter. After the adjustment, click **Loop Detect** again. You will then be able to see the new values (In this case, the Force was changed from 200 to 277, see figure 4.3.5).

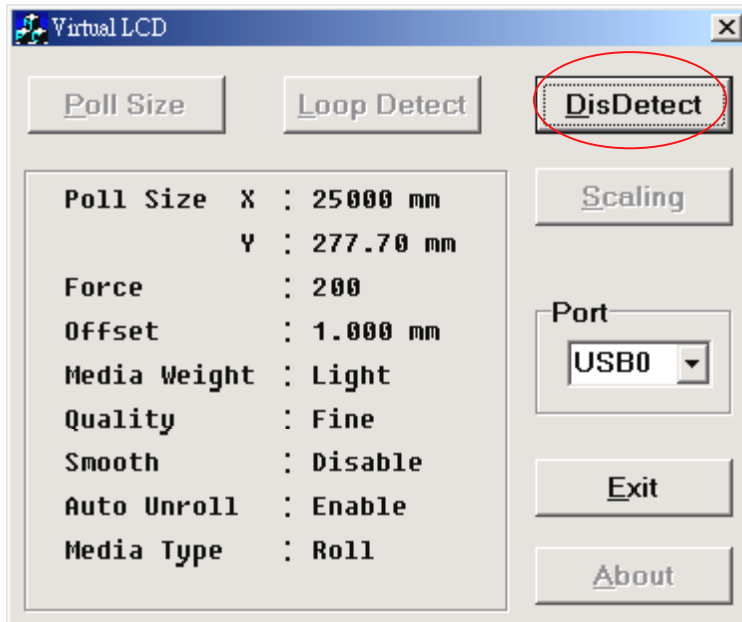

Figure 4.3.4

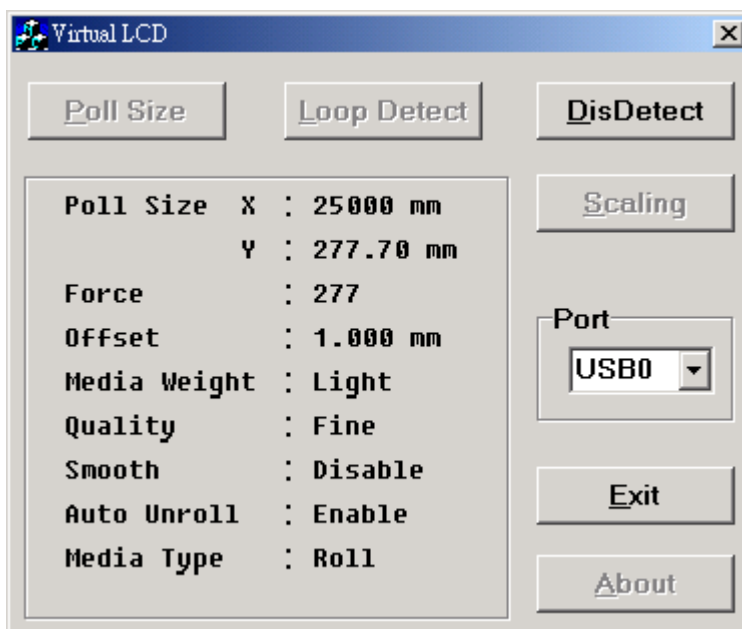

Figure 4.3.5

**Notice!**

One function of the **DisDetect** key is to release the port. Remember to click

**DisDetect** whenever you want to send a job to the cutting plotter or use another device with the port currently used.

---

### C. **Scaling**

Click **DisDetect** and then the **Scaling** key will be enabled (Figure 4.3.6). After clicking **Scaling**, a dialog will pop up (Figure 4.3.7).

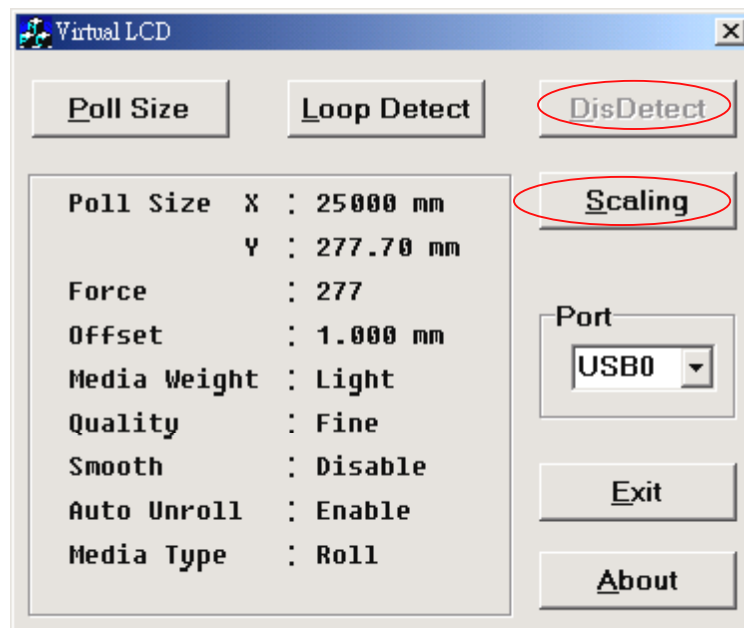

**Figure 4.3.6**

Enter the width and the length of the rectangle that you would like to cut.

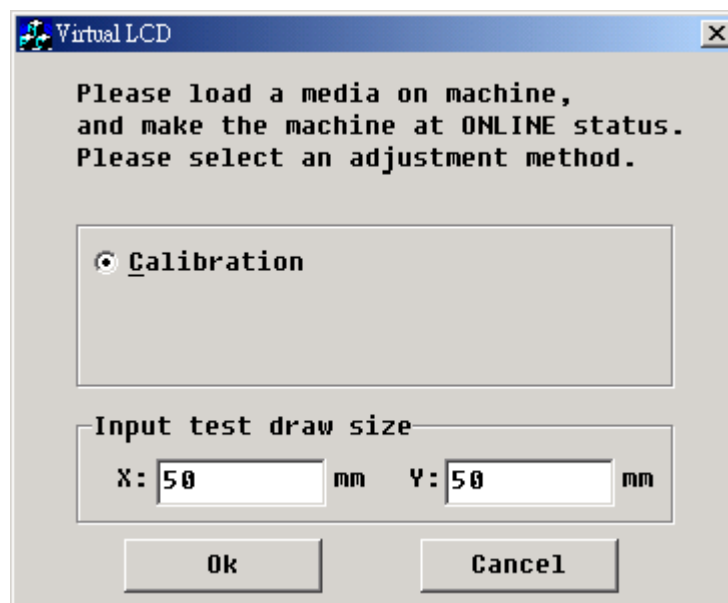

### Figure 4.3.7

After the cutting job is set, an adjustment dialog window will pop up. Measure the real cutting width and length of the rectangle, and then, key in the values in the boxes (Figure 4.3.8). In this case, the actual cutting width of the rectangle is 49mm.

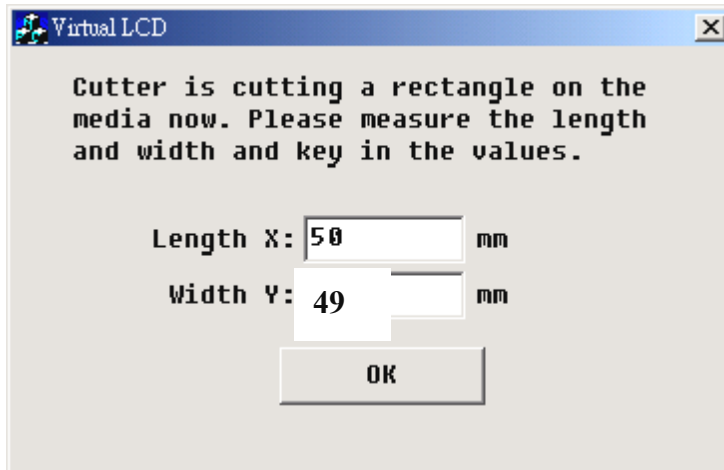

Figure 4.3.8

After pressing **OK**, the cutting plotter will cut the 50mm<sup>2</sup> rectangle again and the following dialog will pop up(Figure 4.3.9). Measure the real cutting width and length. If it is a 50mm<sup>2</sup> rectangle, press **YES**. If not, press **NO**, and repeat the above steps until you get a 50mm<sup>2</sup> rectangle.

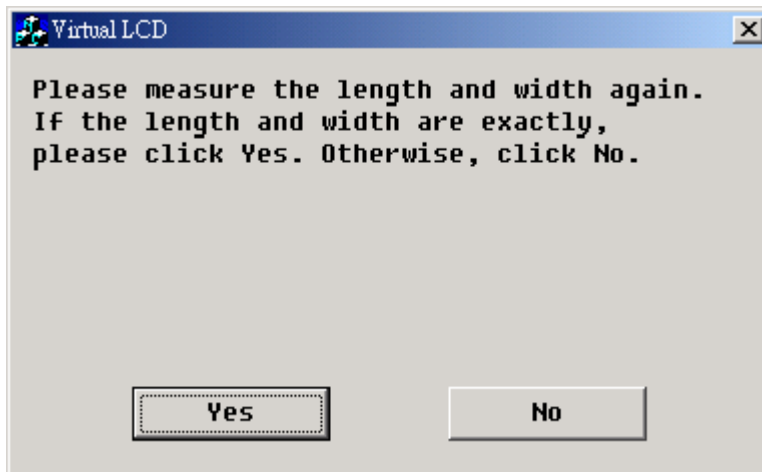
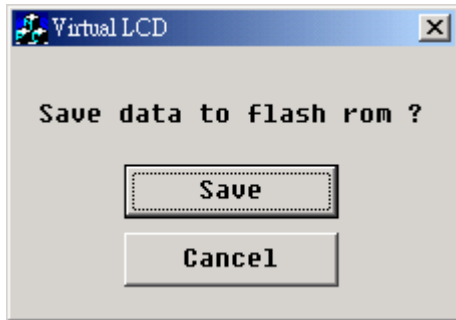

Figure 4.3.9

Remember to click **Save** after the adjustment is made (Figure 4.3.10). The scaling result will be enabled only when the data is saved.



**Figure 4.3.10**

While saving the scaling data, you will be asked to key in a password. Type in 111. (Figure 4.3.11).

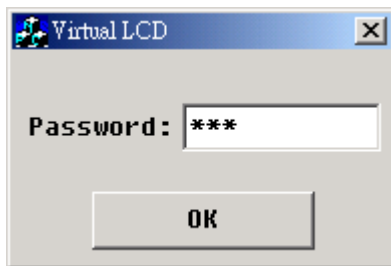

**Figure 4.3.11**

Click **OK** and complete scaling (Figure 4.3.12).



**Figure 4.3.12**

## **D. About**

The **About** key shows you the version of your cutting plotter's firmware and driver (Figure 4.3.13).



**Figure 4.3.13**

## Chapter 5 Basic Maintenance

This chapter explains the basic maintenance (i.e. cleaning the cutting plotter) required for the cutting plotter. Except for the below mentioned, all other maintenance must be performed by a qualified service technician.

### 5.1 Cleaning the Cutting Plotter

In order to keep the cutting plotter under good condition and best performance, you need to clean the machine properly and regularly.

#### Precaution in Cleaning



- ✧ Unplug the cutting plotter before cleaning
- ✧ Never use **solvents, abrasive cleaners or strong detergents** for cleaning. They may damage the surface of the cutting plotter and the moving parts.

#### Recommended Methods

- ❖ Gently wipe the cutting plotter surface with a lint-free cloth. If necessary, clean with a damp cloth or an alcohol-immersed cloth. Wipe with water to rinse off any residue and dry with a soft, lint-free cloth.
- ❖ Wipe all dust and dirt from the tool carriage rails.
- ❖ Use a vacuum cleaner to empty any accumulated dirt and media residue beneath the pinch roller housing.
- ❖ Clean the platen, paper sensors and pinch rollers with a damp cloth or an alcohol-immersed cloth, and dry with a soft, lint-free cloth.
- ❖ Wipe dust and dirt from the stand.

### 5.2 Cleaning the Grid Drum

- ❖ Turn off the cutting plotter, and move the tool carriage away from the area needed to be cleaned.
- ❖ Raise the pinch rollers and move them away from the grid drum for cleaning.
- ❖ Use a bristle brush (a toothbrush is acceptable) to remove dust from the drum surface. Rotate the drum manually while cleaning. Refer to Figure 5-1

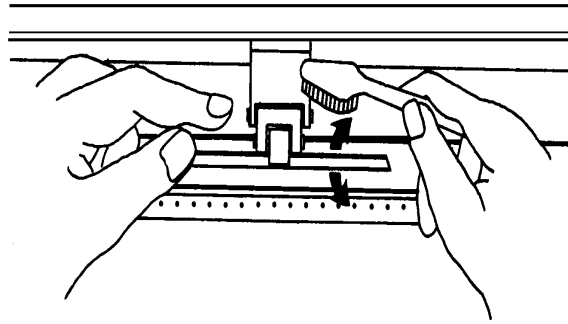

**Figure 5-1**

### **5.3 Cleaning the Pinch Rollers**

If the pinch rollers need a thorough cleaning, use a lint-free cloth or cotton swab to wipe away the accumulated dust from the rubber portion of the pinch rollers. To prevent the pinch rollers from rotating while cleaning, use finger to hold the pinch rollers not to rotate.

If needed to remove the embedded or persistent dust, use the lint-free cloth or cotton swab moistened with rubbing alcohol.

## Chapter 6 Troubleshooting

This chapter helps you to correct some common problem you may come across. Prior to getting into the details of this chapter, please be sure that your application environment is compatible with the cutting plotter.

### Note:

Before calling customer service personnel, please make sure the problems are in your cutting plotter, not from the communication between computer and cutter or a malfunction in your computer or a software problem.



*Why the cutting plotter does not operate?*

### 6.1 If the Cutting Plotter Cannot Operate?

If your Puma doesn't run, please check the following items firstly:

- Does the AC power cord plug in properly?
- Does the AC power cord connected to the power connector properly?
- Do you turn on the power?

#### Solutions:

If the POWER LED lights on, the cutting plotter should be in a normal condition. Switch off the cutting plotter and turn it on again to see if the problem still existing.

**If the POWER LED doesn't light, please call customer service personnel to resolve this problem.**

### 6.2 Lights Indicators







Some of operation problems can be identified by light on the control panel.



When your cutting plotter stops operating or the lights are on or flashing unexpectedly, see the following descriptions of panel light patterns and actions you should take.

### **6.2.1 Warming Indicators**

When the ERROR LED flashes (as show below), take the necessary action according to respective instruction below. If the problems are solved, the ERROR LED will turn off automatically. Press ON/OFF LINE key once can also turn off the ERROR LED.

Warming Indicators		ERROR	ON/OFF LINE	REPEAT	DATA CLEAR	CUT TEST
1	Graph was clipped		●	●	○	○
2	HPGL/2 command Error		●	○	●	○
3	Lever up or no media		●	○	○	○
4	Cannot repeat		○	●	○	○
5	Communication error		○	○	●	○
6	Width sensor error		○	○	○	●
7	Check media, drum or X motor	●	○	○	○	●

 = flash      ● = on      ○ = off

#### **Warming 1. The graph is clipped**

This condition indicates that the cutting graph exceeds the cutting limit.

You can solve the problem by

1. reload the larger media
2. move the pinch roller to have larger cutting width
3. re-scale the plot to a smaller size. Then do the cutting job again from your computer.

### **Warning 2. HPGL/2 command error**

If your cutting plotter cannot recognize the commands from your computer, please check the commands applied to your cutting plotter are HP-GL/2 or HPGL command. Then send the same cutting job to plotter again.

If it shows the same result, please contact customer service personnel.

### **Warning 3 Lever up or no media**

Check if you lower down the lever and be sure to load the media before cutting.

### **Warning 4 Cannot repeat cutting**

This Error comes from two possibilities:

1. The buffer holds no data: please send a new graph from computer;
2. The buffer is full: please sending the same cutting job from the computer again.

In both conditions, press ON/OFF LINE key to clear the warning message.

### **Warning 5 Communication error**

Check if the serial/USB/parallel cables have been connected to both cutting plotter and computer properly.

If yes, then check whether the interface setting is correct.

Check communication setting of your PC are the same to the setting on your cutter(for example – 9600bps, no parity, 8 bits, 1 stop bit). Then, press ON/OFF Line key to switch to on line condition.

### **Warning 6 Width sensor error**

Check if the pinch rollers are positioned above the grid drum and reload the media again.

#### **Note:**

In order to identify the warning easily, please stick the warning sticker (which we put in accessory box) on the side cover of your cutter.

## **6.2.2 Error Indicators**

If some mechanical problems or failure during operations happen, the ERROR LED will turn on. Please follow the instruction below to solve the problem. If the plotter still cannot work, please contact customer service personnel and tell him or her about the error indicators.

	Error Indicators	ERROR	ON/OFF LINE	REPEAT	DATA CLEAR	CUT TEST
1	SRAM error	●	●	○	○	○
2	DRAM error	●	○	●	○	○
3	Check media, drum, or X motor	●	○	○	●	○
4	Check media or Y motor	●	○	○	○	●

 = flash      ● = on      ○ = off

### **Error 1 and 2**

Please contact customer service personnel to replace a new SRAM or DRAM.

### **Error 3 Check media, drum or X motor**

This message indicates that there might be a problem on the **X axis**.

Please check drums are working normally and whether the media is well loaded. Then turn on the power and reboot the cutter.

### **Error 4 Check media, or Y motor**

This message indicates that there might be an obstruction to carriage relating to a problem on the **Y axis**.

Please clear the obstruction and check whether the carriage can move smoothly. Then turn on the power and reboot the cutter.

## 6.3 Cutting Quality Problems

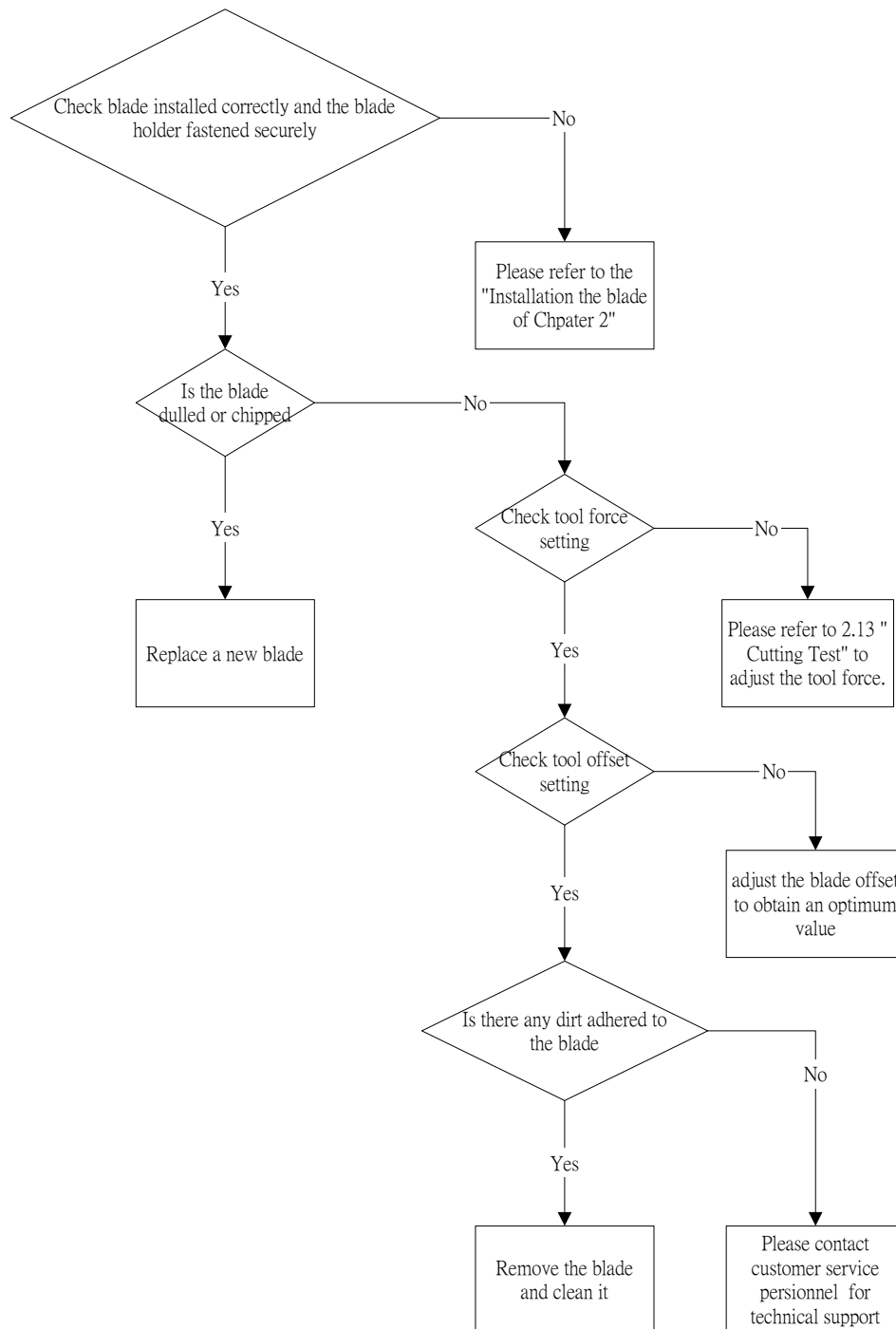

## Appendix I

### Specifications: Puma II PII-132S, PII-60 & PII-30

Model Name/No.	PII-132S	PII-60	PII-30
Operational Method	Roller-Type		
Max. Cutting Width	1300mm(51.18in)	590mm(23.23in)	280mm(11.02in)
Max. Media Loading Width	1470mm(57.87in)	719mm(28.3in)	459mm(18.07in)
Min. Media Loading Width	86mm(3.39")	50mm(1.97")	
Acceptable Material Thickness	0.8mm (0.03 in)		
Number of Pinch Rollers	4	2	
Drive	DC Servo Control		
Cutting Force	0~400 g		
Max. Cutting Speed	Up to 600 mm /sec (23.62 ips)		
Offset	0~1.0 mm		
Mechanical Resolution	0.009 mm		
Software Resolution	0.025 mm		
Distance Accuracy	0.254 mm or 0.1% of move, whichever is greater		
Repeatability	±0.1mm up to 3 meters (* certified media)		
Data Buffer Size	4MB		
Interfaces	USB 1.1 & Parallel (Centronics) & Serial (RS-232C)		
Commands	HP-GL, HP-GL/2		
Configurable Origin	Yes		
Vector Look Ahead	Yes		
Curve & Arc Smoothing	Yes		
Test Cut Possibility	Yes		
Repeat Function	Yes		
Control Panel	10 Control Keys , 6 LEDs		
Dimension (HxWxD) mm	1065 x 1632 x 620 (including stand) 41.93 x62.25x24.41in	220x 879x258 8.67 x34.61x10.16in	220 x 619 x258 8.67 x24.37 x 10.16in
Net Weight	53 kg / 116.4 lb	13kg / 28.6lb	10.2kg / 22.4 lb
Power Supply	AC 100-240V, 50~60 Hz (auto switching)		115V/230V (manual switch)
Environment Temperature	0°C~55°C/32°F~131°F (operating) -40°C~75°C/-40°F~167°F (storage)		
Environment Humidity	30%~ 70% relative humidity (operating)		

\*This specification is subject to change without prior notice.

WWW: <http://www.gccworld.com/>

## Appendix 2

### The Specification for GCC Blade

ZZ00219A For cutting general signage vinyl. Blade with largest angle.

GCB-145S

The blade is 45° with **Yellow Cap**, 0.25 mm blade offset



ZZ00220A For cutting thick fluorescent and reflective vinyl. Also for cutting detailed work in standard vinyl.

GCB-245R

The blade is 45° with **Red Cap**, 0.25 mm offset



ZZ00221A For cutting reflective vinyl, cardboard, sandblast, flock, and stencil sharp edge.

GCB-360SB

The blade is 60° with **Green Cap**, 0.50 mm blade offset



ZZ00222A For cutting thin sandblast mask and stencil with friction feed or sprocket feed machine.

GCB-460SO

The blade is 60° with **Blue Cap**, 0.25 mm blade offset



ZZ00233A For Cutting small text and fine detail. Sharp blade with smallest offset.

GCB-500

The blade is 0.175 mm blade offset with **Black Cap**

